

**KTF!) ) \$!A:**

**Operating Manual**

**Revision 1.3**

**KOREA FLOWMETER IND.CO.,LTD.**

# *Index*

<i>1. Introduction.....</i>	<i>2</i>
<i>1.1 Feature.....</i>	<i>2</i>
<i>1.2 Model Number Designation.....</i>	<i>2</i>
<i>2. Specification.....</i>	<i>3</i>
<i>3. Connection.....</i>	<i>4</i>
<i>3.1 DC Power Connections.....</i>	<i>4</i>
<i>3.2 Input Connection .....</i>	<i>4</i>
<i>3.3 Relay Output .....</i>	<i>5</i>
<i>3.4 Pulse Output .....</i>	<i>6</i>
<i>3.5 Analog Output.....</i>	<i>7</i>
<i>4. Operation.....</i>	<i>7</i>
<i>4.1 Display Information.....</i>	<i>7</i>
<i>4.2 Key-operating method.....</i>	<i>7</i>
<i>4.3 Explain Program menuPulse Output+ .....</i>	<i>7</i>
<i>5. Dimensions .....</i>	<i>13</i>
<i>6. Connection Diagram .....</i>	<i>14</i>

## 1. Introduction

### *1.1 Feature*

KTCE Series Flow Transmitter receives signals from the flow sensor and measures on going flow rate and displays flow rate, the total and accumulated total.

It is connected either to frequency output-type flow sensor. This flow transmitter use two relays(Optional) to function flow alarm, and can add 4–20mA analog output as option.

It changes the signals of flow sensor to the scale pulse before outputting so that other devices can be connected outside to count and display the necessary information in distance.

The LCD display on the front is very convenient to use with a variety of parameters and instructions available to see easily on it. The keys in the front are also easy for you to select and read necessary information, and anyone can program their own values easily on the spot.

The user-set data and the accumulated totals are stored in the EEPROM and are safe for ten years regardless of power-off.

## *2. Specification*

### General

Display 12\*2 characters LCD with LED back light  
Display Update Rate 0.25 seconds

Transducer Supply 12VDC 50mA, 22VDC 50mA  
Operating Temperature 0 to 50°C  
Storage Temperature -20 to 70°C

### Frequency Input

Frequency Range 0Hz to 5KHz  
Signal Type Sine wave, open collector, reed switch, proximity switch, Voltage or current pulse  
K-factor Range 0.0100 to 999,999(the pulse per units)

### Relay Output

Max. Switching Power 60W DC / 100VA AC  
Max. Switching Voltage 220V DC / 250V AC  
Max. Switching Current 2A DC / AC

### 4-20mA Output

Resolution 12-bit  
Accuracy 0.05% of Range  
Maximum Load 500 ohms internally powered. 950 ohms from DC24V  
Isolation Isolated

### Pulse Output Signal

Function The Pulse output is scaled and outputs one pulse each time the total increments.

Output An open collector transistor will sink 50mA max.  
Duty Cycle 49 Pulse/sec. Max.  
Pulse Width 10ms(negative going)

### 3. Connection

#### 3.1 DC Power Connections

DC power can be connected regardless of polar + or –.

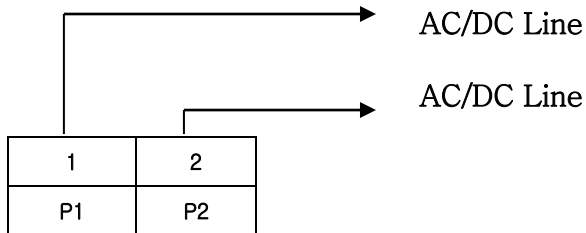

#### 3.2 Input Connection

Input signals are determined to the type of flow meter. So the dual in-line package switches should be set accordingly. Open collector type is the default signal when shipping the order.

When the flow sensor needs power, it can be connected to terminal #1 which releases DC voltage.

Input Signal Type	INTERNAL Terminal			Switch Setting							
	V out	+	-	1	2	3	4	5	6	7	8
1.Open Collector	1	2	3	off	off	off	off	on	off	off	on
2.TTL Logic Pulse	1	2	3	off	off	off	off	off	off	off	on
3.Reed Switch	1	2	3	off	off	off	on	on	off	off	on
4.Coil(20mVp-p min)	1	2	3	off	off	off	off	off	on	off	off
5.Coil(low impedance)	1	2	3	off	on	off	off	off	on	off	off
6.Current Pulse	1	2	3	on	off	off	off	off	off	off	on
7.Namur Proximity	1	1	3	off	off	on	off	off	off	on	on

1. Open Collector

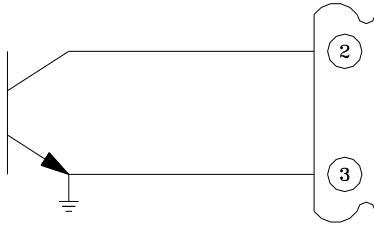

2. Square Wave, CMOS or Logic Pulse

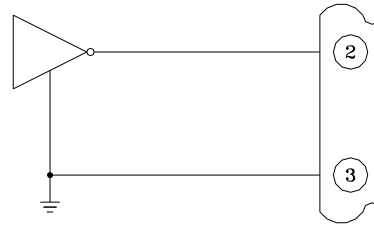

3. Reed Switch

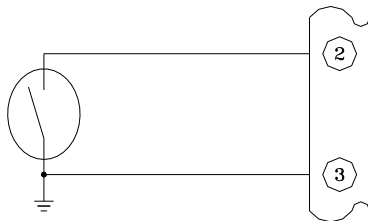

4. Coils

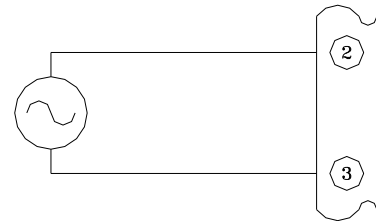

5. Current Pulse

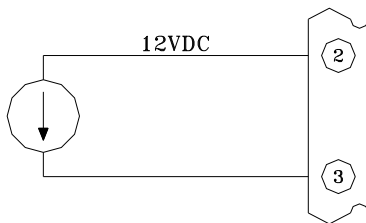

6. Namur Proximity

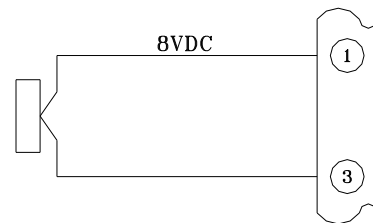

3.3 Relay Output

Two relays are provided to control the external devices. The maximum switching capacity under control is 250VAC@5A or 30VDC@5A. However, it is recommended that you use a separate outside relay even though it is usable within that capacity. It is normally set in open contact by default and the connection is as shown below.

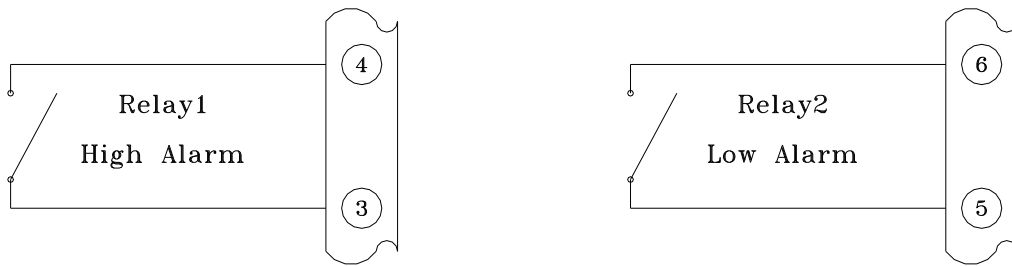

### 3.4 Pulse Output

It's internal circuit is the open collector-type which is why caution should be taken when connecting, as it won't function with wrong polar connections. The width of output pulse is selectable among 10ms, 50ms and 100ms. 10ms is as shown below, in which case the maximum pulse output is 49pulses per second. It is 50mA@30VDC current sink type output so it needs to outsource the power and also needs the current limit impedance.

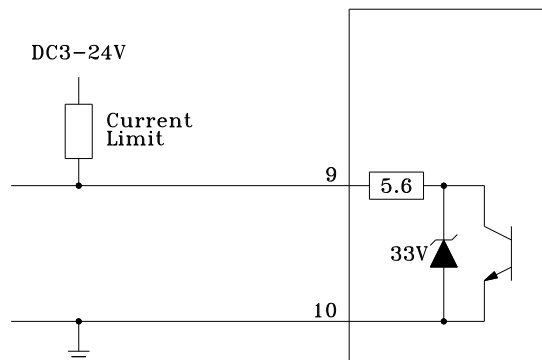

<Output Circuit>

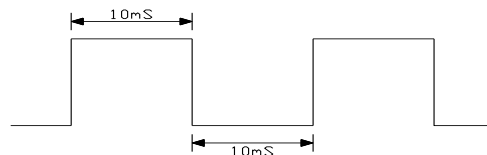

< Output Signal >

### 3.5 Analog Output

It is convert Flow Rate value to 4–20mA signal and output to external device. It is provide Internally powered by the controller type only.

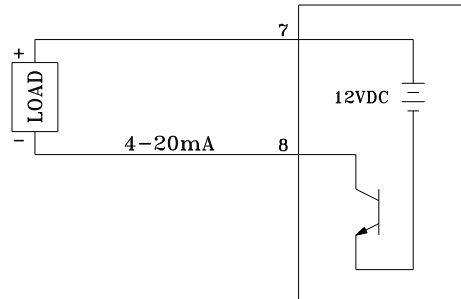

## 4. Operation

### 4.1 Display Information

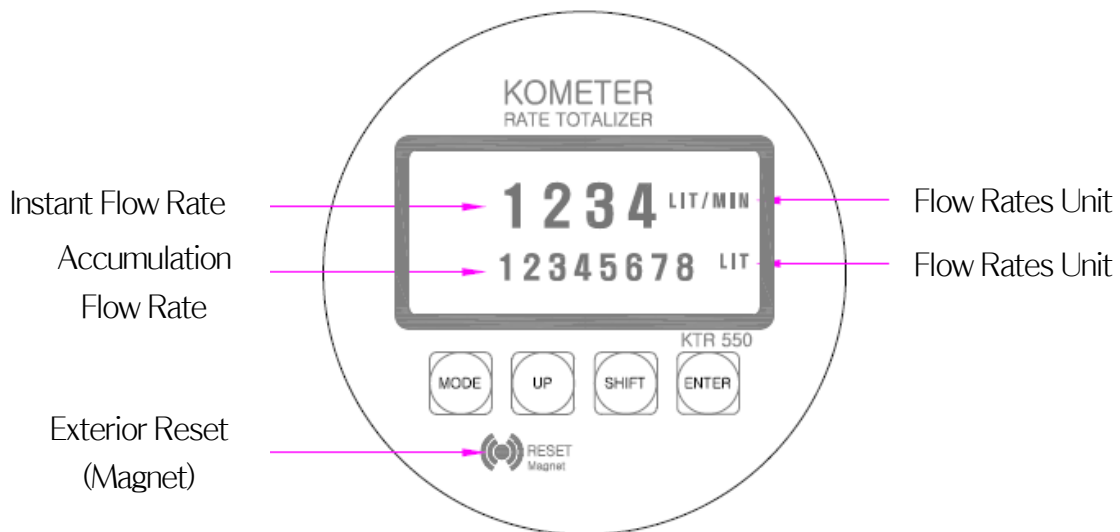

### 4.2 Key-operating method

- 1) MODE Key changes Acc Total to Instant flow rate or Accumulation flow rate and operates pausing for one second.
- 2) UP(SET) Key is used for changing number and toggling menu selecting part Also pausing for three seconds in NORMAL state can enter SETTING mode.
- 3) ENT Key is used for when processing program setting. Also pausing for three seconds in NORMAL state, Accumulation Flow Rate is cleared.

### 4.3 Explain Program menu



1) Accumulation Flow Rate Reset

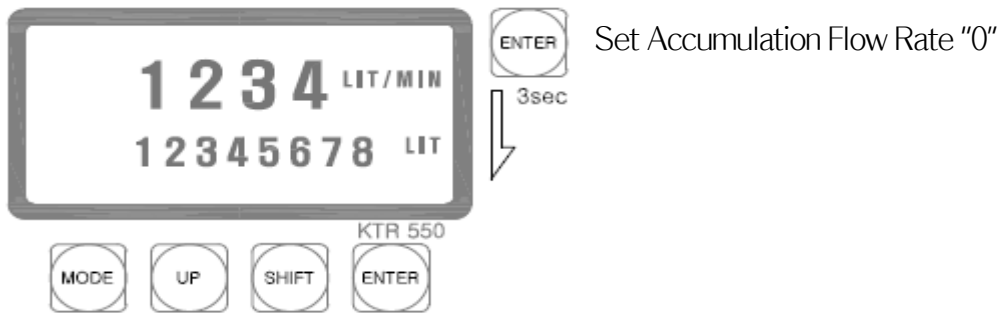

2) Check Total Accumulation Flow Rate / Reset

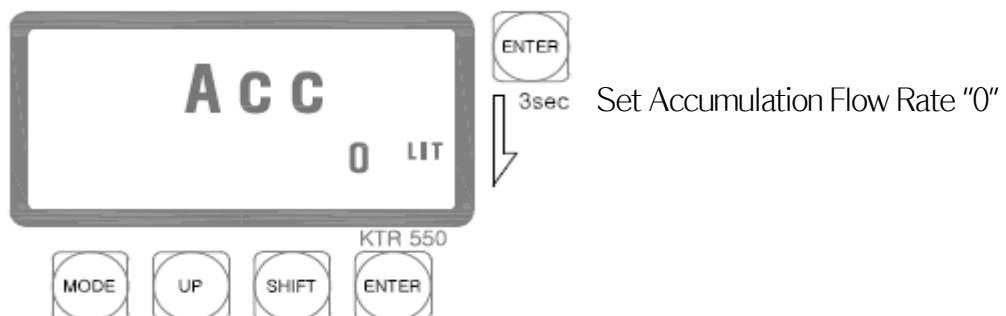
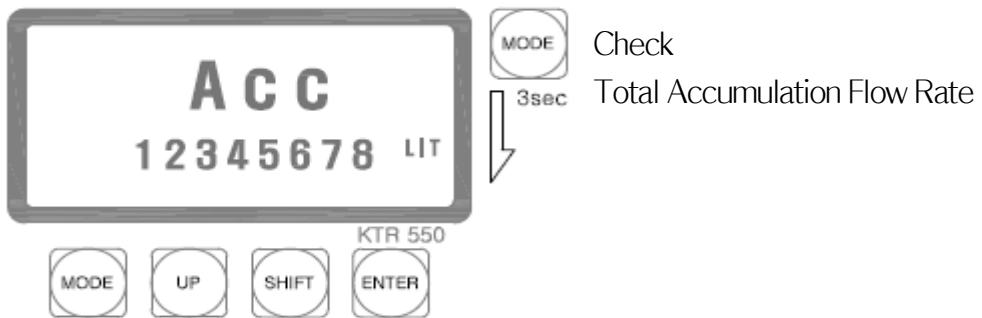

3) Checking / Changing Factor value

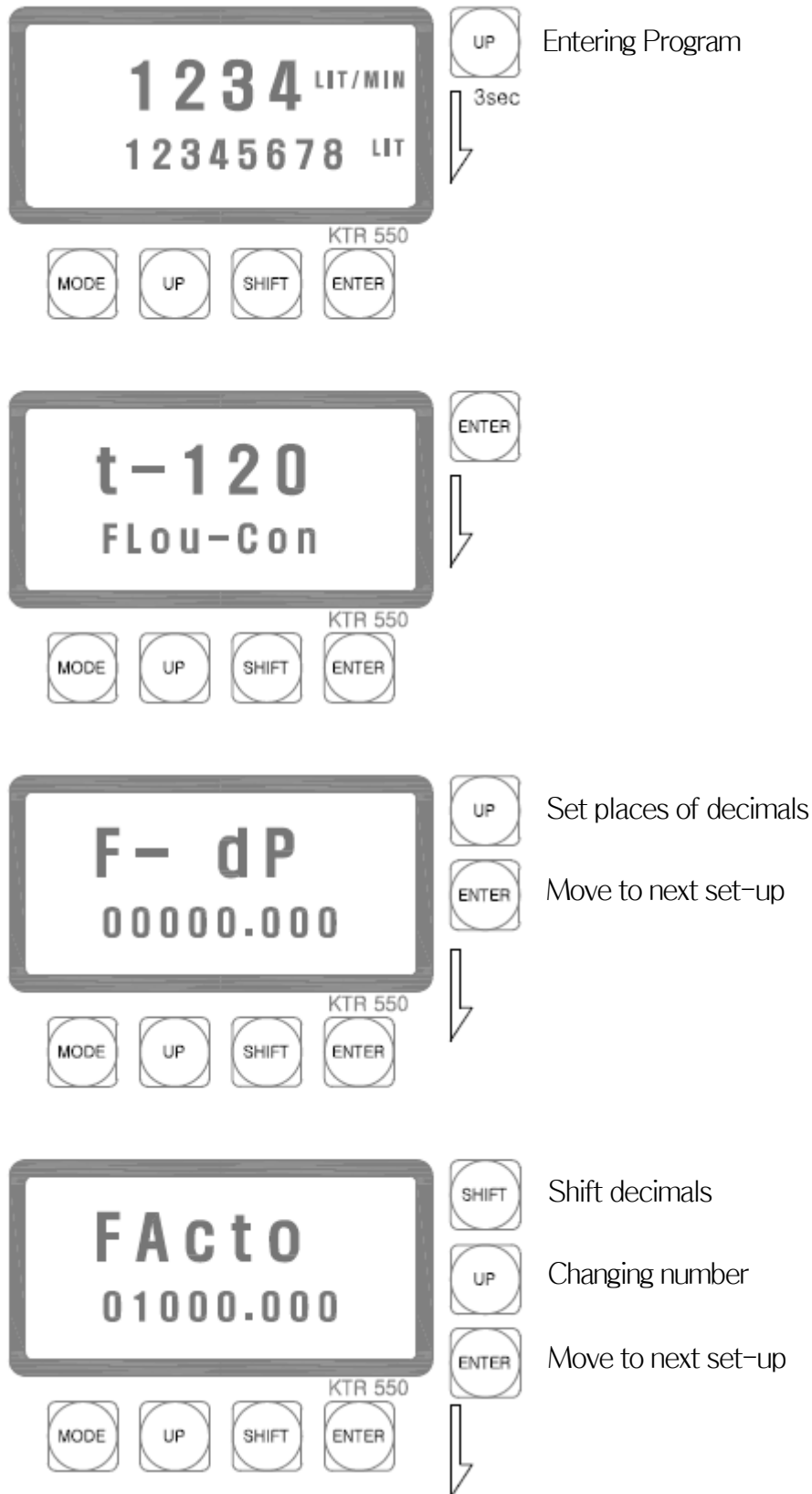

- Factor : When unit of Instant flow rate is m<sup>3</sup>, should set Pulse/ m<sup>3</sup> and also unit of Instant flow rate is Liter, should set Pulse/Liter

#### 4) Changing Unit / Decimal point

Unit LIT/Min  
LitEr LIT

MODE UP SHIFT ENTER

UP Setting up Unit (m<sup>3</sup>, LIT, GAL)  
ENTER Move to next set-up

t-dP  
00.000

MODE UP SHIFT ENTER

UP Sets Accumulation flow rate decimals  
ENTER Move to next set-up

r-dP  
00.000

MODE UP SHIFT ENTER

UP Sets Instant flow rate decimals  
ENTER Move to next set-up

time  
min

MODE UP SHIFT ENTER

UP Setting up Instant flow rate Unit (HR, MIN, SEC, DAY)  
ENTER Move to next set-up

5) Setting up PULSE / Damping

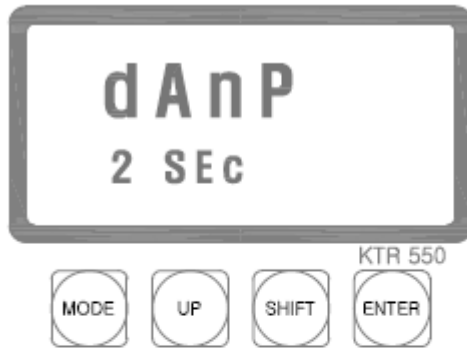

 Setting up Damping  
( no, 2, 4, 6, 8, 10 SEC)

 Move to next set-up



 Setting up Pulse period  
( 20, 50, 100, 200 ms)

 Move to next set-up

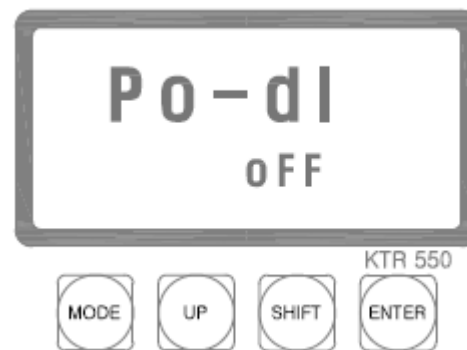

 Setting-up Flow rate / Unit Pulse

 Move to next set-up

누적량 소숫점	설정	1L/Pulse
0000	d1,d10,d100	d/1=1L/1P, d10=10L/1P, d100=100L/1P
000.0	d0,1,d1,d10	d/0.1=0.1L/1P, d1=1L/1P, d10=10L/1P
00.00	d0.01,d0.1,d1	d/0.01=0.01L/1P, d0.1=0.1L/1P, d1=1L/1P
0.000	d0.001,d0.01,d0.1	d/0.001=0.001L/1P, d0.01=0.01L/1P, d0.1=0.1L/1P

6) Setting up 4-20 mA

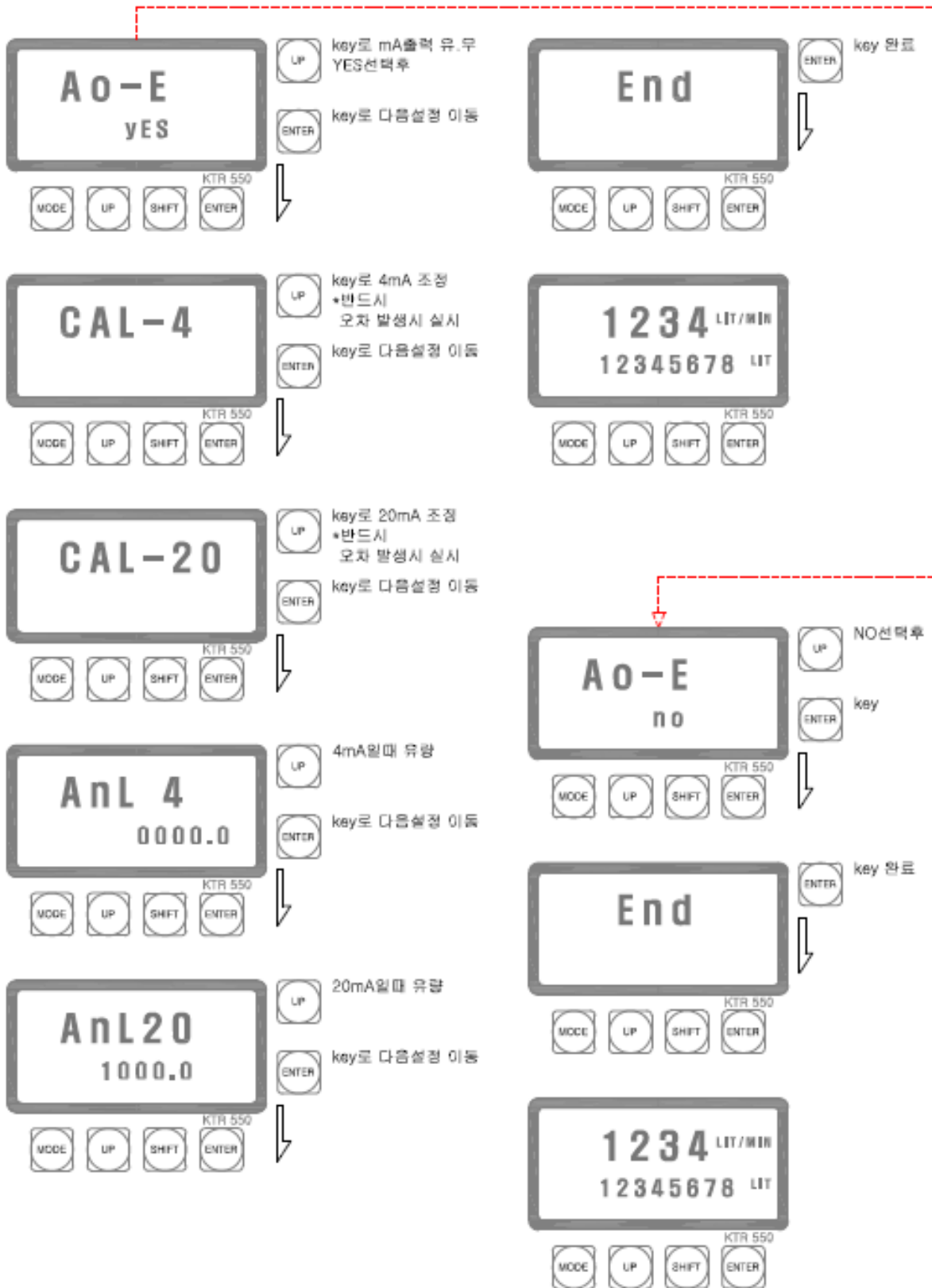

### 5. Dimensions (transmitter)

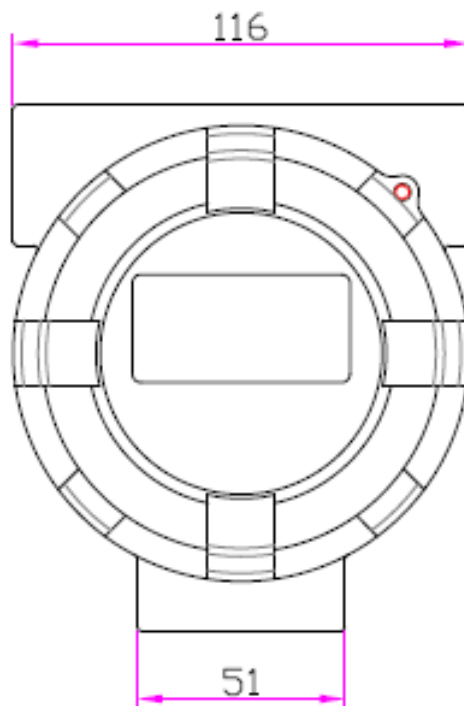
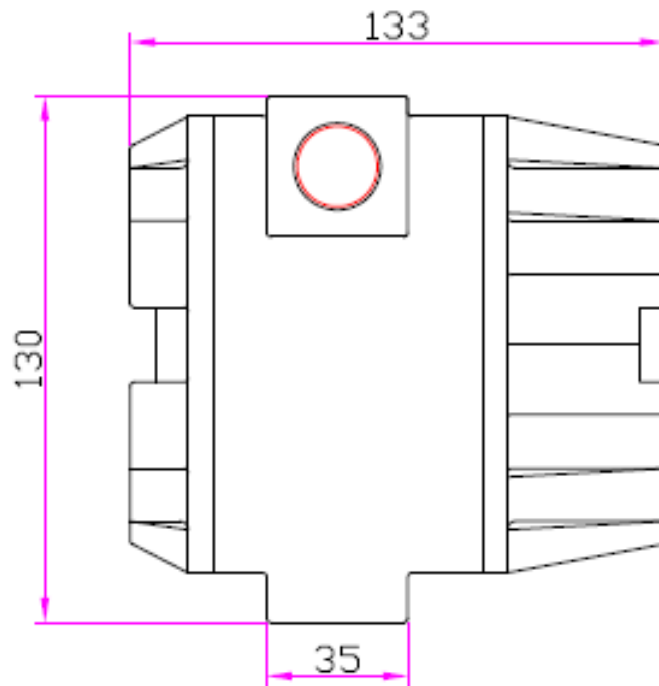

**KOREA FLOWMETER IND.CO.,LTD**

40, Wonchang-ro 64 beon-gil, Seo-gu, Incheon Metropolitan-city, South Korea

Tel + 82-32-584-5301 Fax + 82-32-584-5351

E-mail : [info@kometer.co.kr](mailto:info@kometer.co.kr)